

177 Series

Data Sheet

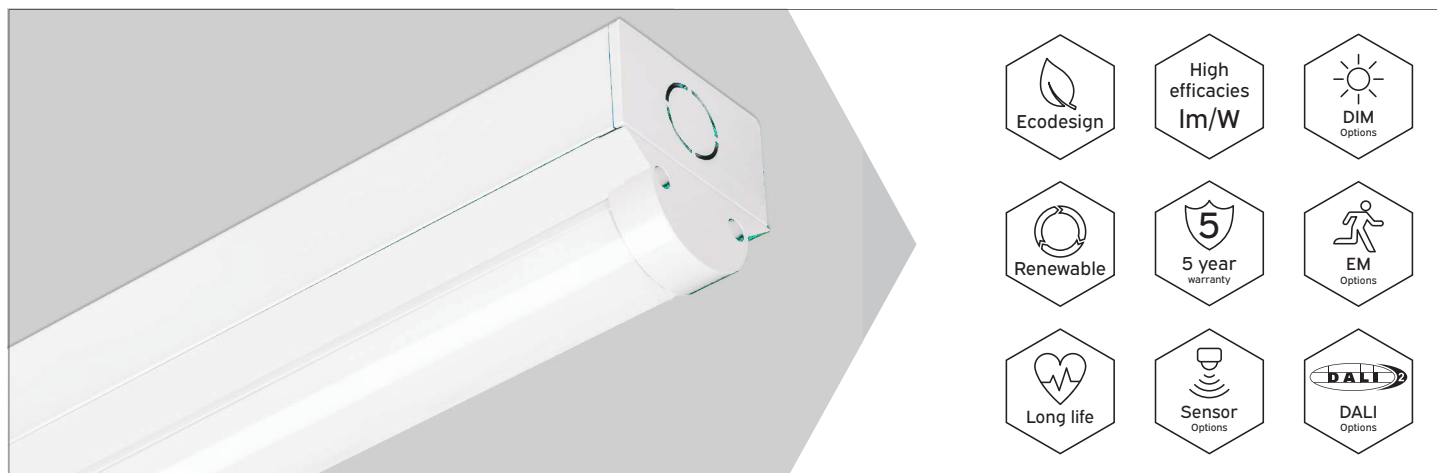

KEY FEATURES

- 4ft LED batten powered by Tridonic
- Aluminium body with integrated gear tray
- Opal diffuser for homogenous output
- BESA fix mounting points
- 20 mm conduit entry points
- High luminaire efficiencies up to 131 lm/tcW
- Long life >50,000h L70/B50
- DALI and emergency options
- Sensor, HubSense and Bluetooth options available
- 5 year warranty

DIMENSIONS

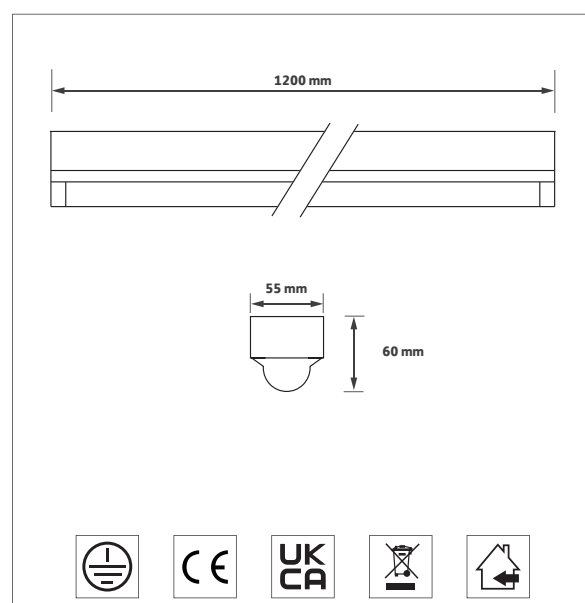

ORDERING INFORMATION

Luminaire output (lm)	Colour temp	Luminaire power (tcW)	Luminaire efficacy (lm/tcW)	Model ref.
2925	840	22.5	130	177.001
3675	840	28.5	129	177.002
4450	840	34.0	131	177.003
5200	840	40.0	130	177.004

OPTIONS

Options	Suffix
Control gear	/ECO
Emergency	/EMI, /EMDI

177 Series

Options

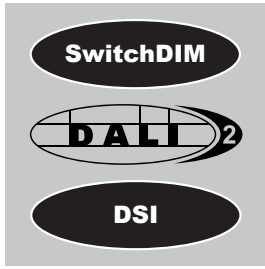

/ECO

SwitchDIM, DALI & DSI

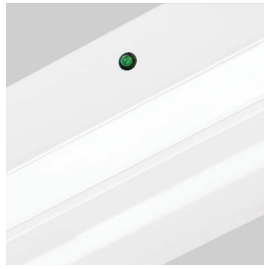

/EMI

Integral emergency

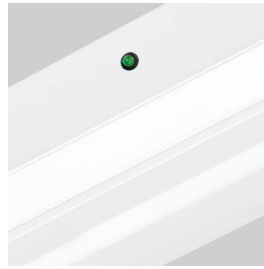

/EMDI

Integral DALI / Self-test
emergency

PV - PRODUCT VARIATIONS

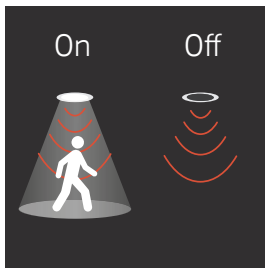

PV - Contact Sales

Integral motion sensor
On / off

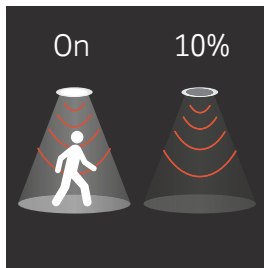

PV - Contact Sales

Integral motion sensor
On / 10% dim



PV - Contact Sales

Casambi wireless
network inc. dimming



PV - Contact Sales

HubSense wireless